

Dimensions of success

The Navigator[®] System

Model-Based Surgery Manual



 **ZimVie**

ZimVie DENTAL SOLUTIONS

Introduction and Treatment Planning

These instructions were designed to serve as a reference guide for dental practitioners utilizing ZimVie Dental implants and Surgical Instruments.

ZimVie Dental's designs enable the practitioner to place implants in edentulous or partially edentulous mandibles or maxillae in order to support fixed and removable bridgework or single tooth crowns and overdentures.

General Information:

The success of any dental implant system depends upon proper use of the components and instrumentation. This manual is not intended for use as a substitute for professional training and experience.

Treatment Planning: Patient Evaluation and Selection

Several important factors must be considered when evaluating a patient prior to implant surgery. The presurgical evaluation must include a cautious and detailed assessment of the patient's general health, current medical status, medical history, oral hygiene, motivation and expectations. Factors such as heavy tobacco use, masticatory function and alcohol consumption should also be considered. In addition, the clinician should determine if the case presents an acceptable anatomical basis conducive to implant placement. An extensive intraoral examination should be undertaken to evaluate the oral cavity for any potential bone or soft-tissue pathology. The examiner should also determine the periodontal status of the remaining teeth, the health of the soft tissue and the presence of occlusal abnormalities such as bruxism or crossbite. The presence of other conditions that could adversely affect any existing natural dentition or healthy soft tissue surrounding the implant should also be evaluated.

Diseases of the mucous membrane and connective tissues, pathologic bone disease and severe malocclusion could affect the determination of whether a patient is a suitable implant candidate.

The use of anticoagulants and the existence of metabolic diseases, such as diabetes, allergies, chronic renal or cardiac disease and blood dyscrasia could significantly influence the patient's ability to successfully undergo implant procedures. If the patient's medical history reveals an existing condition or signals a potential problem that may compromise treatment and/or the patient's well-being, consultation with a physician is recommended.

Preoperative Planning:

The Navigator Model-Based Application provides clinicians the option for utilization of Surgical Guides with the Navigator Instrumentation for cases where a CT scan and virtual planning software may not be necessary.

Preoperative treatment planning is performed by means of traditional X-ray assessment and appropriate analog placement within the Master Cast. The option for minimally

invasive surgery and laboratory fabrication of a provisional prosthesis are made possible with this application. Proper treatment planning includes the selection of appropriate implant lengths, diameters and locations. The number of implants is a fundamental consideration for the long-term success of an implant supported restoration. It is recommended that for patients requiring more than three implants, clinicians utilize the benefits of CT guidance. Before an implant is placed, the anatomical foundation of the treatment area must be carefully assessed. The use of a CT scan is necessary for patients who may present with challenging anatomical scenarios or when working in close proximity to vital structures.

During the presurgical restorative planning phase of cases with immediate provisionalization, it is important for the surgeon, restorative dentist and laboratory technician to participate in determining the type of prosthesis and restorative components that will be used. Such decision making is critical for determining the location of implants and should be finalized prior to implant surgery. A top-down treatment planning approach is recommended, whereby the final prosthesis is designed, implant locations are determined and restorative components are selected prior to initiating implant surgery.

Clinical information necessary for determining appropriate treatment options includes but is not limited to: determining vertical dimension, evaluating the space available between the alveolar crest and the opposing dentition to confirm that space exists that accommodates the proposed abutment and final restoration, locating the position of important anatomic structures and determining bone dimensions where implants are to be placed. The height required by the restorative components varies with the type of abutment. Therefore, the surgeon and restorative dentist should carefully evaluate abutment dimensions. Diagnostic casts should be used preoperatively to evaluate the size of the residual ridge and to determine the position and angulation of all implants. These casts allow clinicians to evaluate the opposing dentition and its effect on implant position. A Surgical Guide is helpful in determining the precise intraoral position and angulation of the implants and should be included in the preoperative treatment plan.

By visualizing the final design of the prosthesis prior to implant surgery, both restorative and surgical clinicians have the opportunity to identify potential restorative obstacles. They can then make the necessary modifications to implant selection, location and the overall treatment plan prior to actually placing the implants, thus improving treatment predictability and success.

Table of Contents

Navigator Model-Based Surgery:

Steps to Success	1
Instrumentation Overview	3
Surgical Plan Overview	7
Tips and Techniques	8
Immediate Provisionalization Option	9
Diagnostic Mapping of Patient Anatomy	10
Laboratory Fabrication of the Master Cast	12
Fabrication of the Surgical Guide Based on the Laboratory-Made Master Cast	14
Laboratory Abutment Selection	16

NOTE: Images shown throughout this manual are representational in nature and may not be to scale or display the exact geometry or color of the actual components.

Navigator Model-Based Surgery

Steps to Success

Diagnostics

1. Treatment planning and diagnostic evaluation are done prior to the surgical appointment. Impressions are made at this time in preparation for fabrication of the diagnostic cast.
2. The length, diameter and body style of the implant(s) are selected and tentative positions are planned. Periapical and panoramic radiographs are used to identify adjacent tooth roots and other important anatomical structures.

Laboratory Fabrication and Use of the Mapping Appliance

3. A translucent appliance is fabricated from the diagnostic cast in the laboratory. Perforations in the appliance are made corresponding to the tentative position of the planned implant(s).

Diagnostic Mapping of Patient Anatomy

4. The patient is locally anesthetized. Tissue depth is measured with a periodontal probe and an endodontic rubber stopper. The measurements will be communicated to the dental laboratory technician.

Laboratory Fabrication of the Master Cast

5. The above measurements, appliance and the treatment plan are sent to the dental laboratory to be used in conjunction with the ZimVie Dental Navigator Laboratory Kit.
6. The diagnostic cast is sectioned where the implants are intended to be placed, becoming the master cast in preparation for implant analog placement.
7. Implant analogs are placed into the implant sites in the sectioned master cast according to the specified treatment plan.

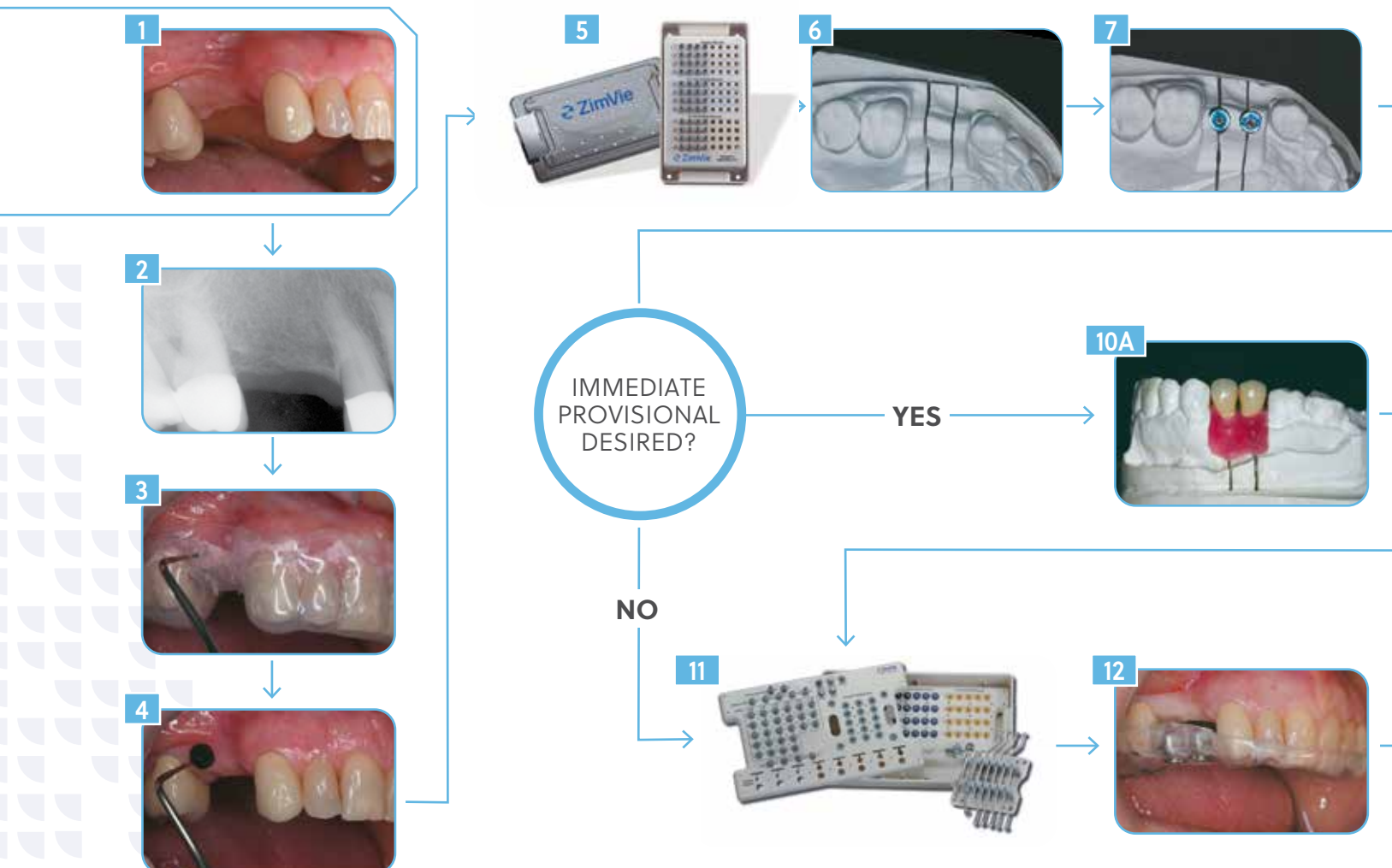

Planning

8. The case-specific Surgical Plan is generated by providing the intended implant catalog number and determining the appropriate Navigator Analog Mount for each site.
9. The Navigator Analog Mounts with the master cast are used to appropriately position the Master Tubes during Surgical Guide fabrication.

Provisional Restorations

This laboratory protocol can be used with immediate, two-stage and single stage protocols. Provisional restorations can be fabricated consistent with the selected protocol.

10. The provisional prosthesis is fabricated for use with an immediate loading protocol.
11. The Surgical Guide, Surgical Plan, cast and provisional restorations are sent to the clinician for implant placement using the ZimVie Dental Navigator Surgical Kit.

Surgical Procedures

12. The Surgical Guide is placed on the adjacent natural teeth.
13. The clinician prepares the osteotomies according to the case specific Surgical Plan with the Surgical Guide and the ZimVie Dental Navigator Surgical Kit.
14. The implants are placed through the Surgical Guide with the use of the Navigator Implant Mounts. The mounts guide implant placement while allowing for control of the implants' hex orientation.
15. The implant loading protocol is determined at the time of placement.
16. A provisional abutment(s) and restoration(s) are delivered.
17. The patient leaves the office with the provisional restorations and a new smile.

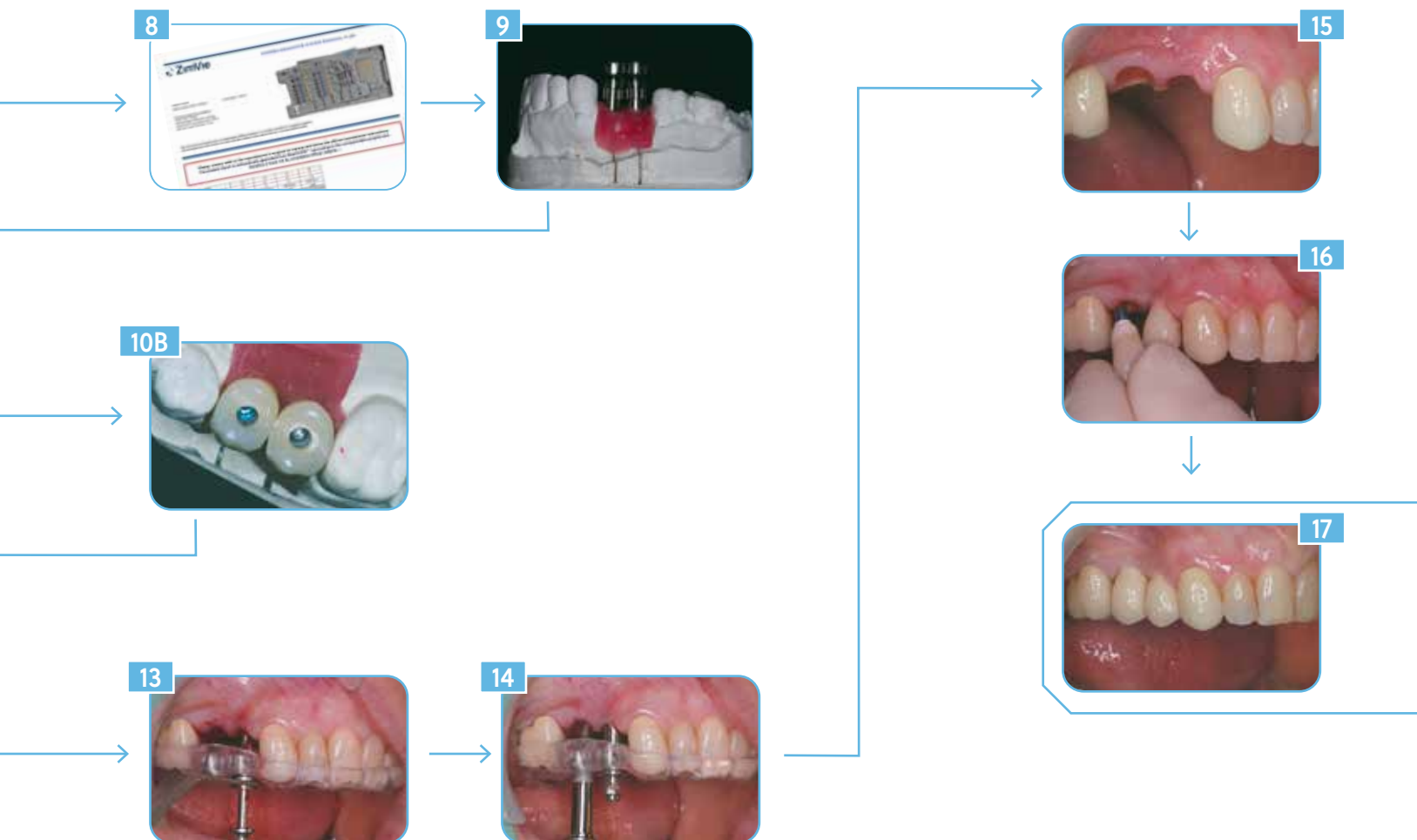

Instrumentation Overview

The ZimVie Dental Navigator System was developed in response to clinicians' growing interest in minimally invasive dental implant placement and the desire to accelerate patient provisionalization. The ability to perform guided surgery with traditional laboratory procedures allows for the use of the Navigator System without a CT scan or planning software.

The use of a Navigator Model-Based Surgical Guide allows for the preoperative determination of implant location, depth, angulation and hex orientation. The laboratory fabricated Surgical Guide then allows for implant placement based on this pre-determined treatment plan.*

The Navigator System can be used to fabricate a provisional prosthesis prior to implant placement based on the contours of a master cast and tissue depth measurements of the patient. The Surgical Guide built from this cast enables placement of the implants and the option to deliver the provisional restoration immediately following surgery. The system allows clinicians to place dental implants in predetermined locations with proper hex orientation. This feature is especially beneficial for single-unit and cement-retained provisional restorations. It offers clinicians the option to deliver a provisional prosthesis the day of surgery, as well as the option to perform flapless surgery.

The ZimVie Dental Navigator System includes the Navigator Surgical Kit and the Navigator Laboratory Kit and supports the placement and restoration of Certain® Parallel Walled 3.25 mm, 4 mm and 5 mm Implants, Osseotite XP® 4/5 mm Implants, Prevail® Expanded Platform 3/4/3 mm, 4/5/4 mm and Prevail Straight Collar 4/3 mm and 5/4 mm Implants. With this design, ZimVie Dental is able to complement the use of a wide range of prosthetic options.

To stabilize the Surgical Guides intraorally, a 2 mm Fixation System (31-3100) is available through ZimVie Dental Microfixation. To order this Fixation System, please contact ZimVie Microfixation at 1-800-874-7711.

Master Tubes

Master Tubes guide instruments through the Surgical Guide. These provide predetermined depth stops for the Twist Drills, Implant Mounts and Analog Mounts, while providing hex orientation and positioning between the lab analog and clinical implant placement. The Master Tubes are positioned in the Surgical Guide at the time of Surgical Guide fabrication.

The "slot" feature on the Master Tubes engages the anti-rotational pin on the Analog Mounts. This allows for accurate transfer of the hex orientation of the analog during Surgical Guide fabrication. This feature also allows for alignment of the Implant Mounts and implants during surgery.



Navigator Surgical Kit



Navigator Laboratory Kit



Laboratory Kit Components

Implant Analog Mounts

The Navigator Laboratory Kit is comprised of Implant Analog Mounts for Navigator Model-Based Surgical Guides. The mounts are used to position the Master Tubes in the Surgical Guide. The laboratory kit, like the surgical kit, contains twelve unique mounts with the Certain Internal Connection. These mounts are available in three platform diameters (3.4 mm, 4.1 mm and 5.0 mm) and four lengths identified as (1), (2), (3) and (4). Because a specific Analog Mount may be required multiple times, four complete sets of Analog Mounts are available in the kit, for a total of 48 Analog Mounts. The Analog Mounts feature a mechanical-locking system to hold the Master Tubes in place in relation to the analogs of the master cast during guide fabrication. An anti-rotational pin on the Analog Mount is aligned with one of the slots on the Master Tube to provide for accurate transfer of the hex orientation from the preoperative master cast to the Surgical Guide and finally to the implants intraorally.



Surgical Kit Components

Implant Mounts

Implant Mounts are used through the Master Tubes in the Surgical Guide to place implants. The Implant Mounts have the Certain Internal Connection and are available in three platform diameters (3.4 mm, 4.1 mm and 5.0 mm) and four lengths identified as (1), (2), (3) and (4), for a total of twelve unique Implant Mounts. Because a specific Implant Mount may be required multiple times, five complete sets of Implant Mounts are available in the kit, for a total of 60 Implant Mounts. Implant Mounts are depth specific with a flange for depth control. A "spline" feature on the flange can be used as a visual reference during implant placement to orient the hex connection of the implant. The cutouts on the flange are aligned with the slots on the Master Tube to ensure accurate transfer of the hex orientation from the preoperative master cast to the mouth.



Tissue Punches

Tissue Punches are used through the Master Tubes in the Surgical Guide to remove soft tissue for flapless surgery. The Tissue Punches are available in two diameters (4.0 mm and 5.0 mm) and one length. These contain depth markings of (1), (2), (3) and the top of the Tissue Punch (4) that correspond with the Depth Line indicated in the Surgical Plan (protocols) for use during surgery. The recommended drill speed is 300-500 rpm, with irrigation.



Tissue Punches

Starter Drills are used through the Master Tubes in the Surgical Guide to perforate the cortical plate, create a 2 mm pilot hole and countersink for the osteotomy. The Starter Drills are available in five platform configurations (3.4, 3/4, 4.0, 4/5 and 5.0 mm) to countersink for different implant collar shapes. These contain depth markings of (1), (2), (3) and the top of the Starter Drill body (4) to correspond with the Depth Line indicated in the Surgical Plan (protocols) for use during surgery.

The recommended drill speed is 1200-1500 rpm, with irrigation.



Drill Positioning Handles

The handles contain drill guide tubes that fit precisely within the Master Tubes of the Surgical Guide to provide guidance and depth control of the Twist Drills during preparation of the osteotomy. There are five handles; (1) and (2) for use with 4.1 mm Master Tubes and Handles (3), (4) and (5) for use with 5.0 mm Master Tubes. These contain drill guide tubes to accommodate the various drill diameters (2.0 mm, 2.75 mm, 3.0 mm, 3.25 mm, 3.85 mm and 4.25 mm).



Twist Drills

Twist Drills are used to prepare the osteotomy for implant placement. Once the Surgical Guide is in place, the Drill Positioning Handles with drill guide tubes are inserted into the Master Tubes of the Surgical Guide. The Twist Drills are inserted through these guide tubes. The drills are depth-specific without depth lines and contain flanges to stop the drills when these make contact with the drill guide tube component of the Drill Positioning Handles. Twist Drills are available in six diameters (2.0 mm, 2.75 mm, 3.0 mm, 3.25 mm, 3.85 mm and 4.25 mm) to allow surgeons to appropriately size osteotomies based on observed bone densities and clinical preference. There are five drill lengths included in the kit (A, B, C, D, E).

The recommended drill speed is 1200-1500 rpm, with irrigation.

The drills included in the surgical kit will accommodate the majority of possible scenarios. Special drills required for a very small percentage of cases have been left out to simplify the surgical kit. In these special cases, Y or Z length drills may be prescribed by the Surgical Plan. These drills may be purchased separately as needed.

NOTE: Drill lengths do not necessarily correspond to implant lengths; rather these are dictated by the Surgical Plan (protocols) based on the prolongation (distance between the position of the Master Tubes and implant seating surface).



Bone Taps

Bone Taps are used through the Master Tubes in the Surgical Guide to thread a 5.5 mm vertical section of the osteotomy prior to implant placement. The Bone Taps are available in four diameters (3.25 mm, 4.0 mm, 4/5 mm and 5.0 mm) and one length. These contain depth markings (1), (2) and (3). At (4) the Bone Tap body has a depth stop. These markings correspond with the Depth Line indicated in the Surgical Plan (protocols) for use during surgery.

The recommended drill speed is 15-20 rpm.



Implant Staging

The Navigator Surgical Kit contains eight implant holder slots to receive the inner packaging of ZimVie Dental Implants, similar to existing surgical kits. Implants will be manually pre-mounted here in preparation for placement.

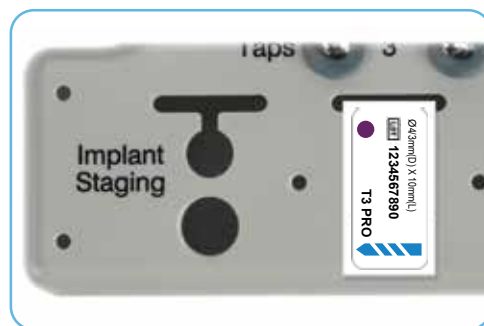

Bone Profilers

Hand-held Bone Profilers are available to manually remove crestal bone for proper abutment seating after implant placement. These are available in three platform diameters: 3.4 mm, 4.1 mm and 5.0 mm and are utilized once the Surgical Guide has been removed.

Miscellaneous Instruments

Miscellaneous standard drivers and ratchets are included in the system to place ZimVie Dental Implants. These tools include the following: PHD02N, RASH3N, MDR10, CW100, WR150, RE100 and RE200.



Surgical Plan Overview

The Navigator System works in conjunction with the ZimVie Dental generated Surgical Plan. This case-specific plan provides direction regarding the instrumentation that will be used for each implant site during surgery.

Surgical Plan Legend

1. Tooth number and implant position
2. Specifies preparation depth for the Tissue Punch, Starter Drill and Bone Tap. A Depth Line of (2) indicates use up to the second depth indicator on the instrument
3. Indicates a 4.0 mm diameter Tissue Punch
4. Indicates a 4.1 mm diameter Starter Drill
5. Indicates a 2.0 mm diameter twist drill with a drill length of (B) to be used in conjunction with Handle 1
6. Indicates a 4.0 mm diameter Bone Tap
7. Indicates a 4.1 mm diameter Implant Mount with a depth of (2)
8. Indicates a 4.1 mm hand-held Bone Profiler
9. Indicates a 4.1 mm diameter Analog Mount with a depth of (2)
10. Specifies that a 4.1 mm implant analog should be utilized for laboratory purposes

Implant Label	10	11	13
Implant Reference Code	NIOS411	NIOS413	NIOS510
Planned Implant Diameter (mm)	4	4	5
Planned Implant Length (mm)	11.5	13	10
Implant Placement			
Depth Line	(2)	(3)	(3)
Tissue Punch	4	4	5
Starter Drill	4	4	5
Drill / Handle	2.0(B) / 1	2.0(C) / 1	2.0(B) / 3
Drill / Handle	3.0(B) / 2	3.0(C) / 2	3.25(B) / 4
Drill / Handle	---	---	3.85(B) / 4
Tap	4	4	5
Implant Mount	4(2)	4(3)	5(3)
Bone Profiler	4	4	5
Analog Placement			
Analog Mount	4(2)	4(3)	5(3)
Analog Type	IILA20	IILA20	IILAW5

The Surgical Plan specifies the Depth Line for instruments that pass directly through the Surgical Guide Master Tubes including the Tissue Punch, Starter Drill and Bone Taps. These instruments have landmarks referenced as (1), (2), (3) and (4) that indicate the proper depth to which these instruments should be used through the Master Tubes [Figure 1]. There are three lines on each instrument; the first line represents Depth Line (1), while the top of the instrument represents Depth Line (4). The instruments pass directly through the Master Tube until the center of the specified line on the instrument reaches the top of the Master Tube [Figure 2].

The Depth Lines also determine what Implant Mount and Implant Analog Mount must be used. These are labeled by diameter and length. Therefore an Implant Mount for a 4.0 mm implant that has a Depth Line of (3) will be specified as 4(3).

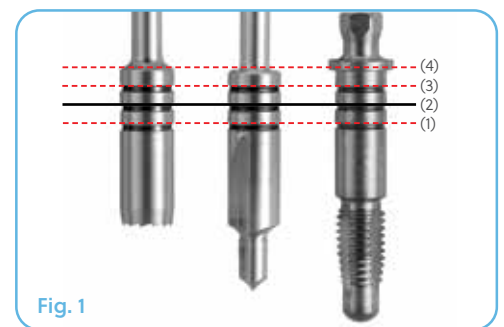

Fig. 1



Fig. 2

Tips and Techniques

Planning

- Be sure that the case has sufficient bone volume for guided surgery. Plan the case with accurate panoramic and periapical radiographs.
- In patients requiring more than three implants, clinicians should utilize CT Guidance. For patients who may present with challenging anatomic scenarios or when working in close proximity to vital structures, a CT scan is necessary.
- Implants currently compatible with the Navigator System Include:
 - Certain Internal Connection Parallel Walled 3.25 mm, 4.0 mm and 5.0 mm Implants
 - Osseotite XP 4/5 mm Implants
 - Prevail Expanded Platform 3/4/3 mm, 4/5/4 mm and Prevail Straight Collar 4/3 mm and 5/4 mm Implants
- Heights of the Master Tube above the implant platform are variable (3.5 mm, 5.0 mm, 6.5 mm, 8.0 mm). This is determined at the time of model-based Surgical Guide fabrication.
- When working in tight interdental spaces, ensure that there is sufficient space for the Master Tube to fit between existing dentition or closely planned implants. For a single-unit case, an interdental space of 7.5 mm is needed for a 4.1 mm Master Tube (5.5 mm for the tube itself, with 1.0 mm of space on either side) and 8.5 mm for a 5.0 mm Master Tube (6.5 mm for the tube itself, with 1.0 mm of space on either side).

Preparation

- Inspect the Surgical Guide for imperfections and reinforce potential weak areas of the Surgical Guide with acrylic resin.
- In the event that the guide may need adjustments, try-in the Drill Positioning Handles to allow the Drill Positioning Handles to fully seat.
- Clear the Master Tubes of any material remaining from Surgical Guide fabrication.
- Score the Master Tube notch positions on the Surgical Guide to record the hex orientation landmarks.

Clinical Use

- For flapless cases, use a Tissue Punch through the guide, prior to fixation of the guide. Remove the guide and remove the tissue plugs. The Tissue Punch is not intended to be used at high speeds and should be used at no greater than 300–500 rpm.
- All instrumentation should be advanced as far as possible through the Master Tube or the drill positioning handle guide tube before rotating. This will limit the possibility of damaging either the instruments or the tubes.
- Use irrigation on instruments prior to and during use to provide lubrication when passing through the Master Tubes and/or Drill Positioning Handles.
- Place all implants close to the final vertical position with the handpiece, then use the hand ratchet to achieve final vertical position and hex orientation.
- Use Bone Profilers prior to placing abutments of any type. Use an oversized profiler when placing angulated abutments.

Immediate Provisionalization Option

A key benefit of using the ZimVie Dental Navigator System is the option to create a preoperative fixed provisional restoration prior to the day of surgery, based on the master cast used to fabricate the Surgical Guide. In appropriate situations, this may allow the clinician to insert a provisional restoration immediately following implant placement using the Surgical Guide and provide the patient with an aesthetic and functional prosthesis the same day as the surgery.

Pages 13-20 in this manual are designed to guide surgeons, restorative clinicians and laboratory technicians through the process of fabricating a preoperative master cast and model-based Navigator Surgical Guide, to allow for the placement of ZimVie Dental Implants using the Navigator System. For more information regarding the provisional restoration options associated with the Navigator System, please refer to the Navigator Manual.

The provisional prosthesis may be fabricated using a variety of ZimVie Dental Provisional Components. These components and manual guidelines were developed to provide an easy way to deliver an accurate fitting provisional restoration on the day of surgery regardless of potential error from cast fabrication, Surgical Guide creation or implant placement. When selecting the provisional component, it is important to identify the type of definitive prosthesis and the abutment system that will be used to create it. The chart below includes recommendations that a clinician may want to consider for provisional component selection dependent upon the type of definitive restoration planned.

Provisional Component	Seating Platform	Provisional Restoration	Final Restoration
PreFormance® Posts	Direct to Implant	Cement-Retained	Cement-Retained or Screw-Retained
PreFormance Temporary Cylinders / Titanium Temporary Cylinders	Direct to Implant	Screw-Retained	Cement-Retained or Screw-Retained
Provide® Temporary Cylinders	Abutment Level (For Provide® Abutments only)	Cement-Retained	Cement-Retained
QuickBridge® Provisional Components	Abutment Level (For Conical Abutments only)	Cement-Retained	Screw-Retained

Diagnostic Mapping of Patient Anatomy

Clinician

1. Determine/assess the width of the ridge crest and the amount of keratinized tissue. If there is a limited amount of keratinized tissue available, a full thickness mucoperiosteal flap is recommended to maximize the volume of keratinized tissue for the implant restoration.

Make impressions of the jaws in preparation for fabrication of the diagnostic casts.

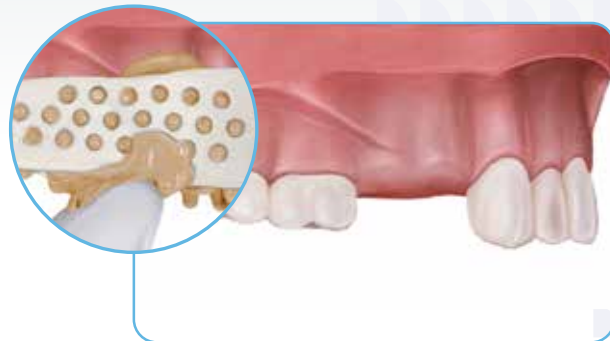

2. The length, diameter and orientation of the implant(s) should be considered prior to the fabrication of the diagnostic cast. Analyze the orientation of the roots of the adjacent natural teeth to avoid these during preparation of the osteotomies and implant placement. Use periapical and panoramic radiographs for these assessments.

NOTE: *This technique should only be used when there are natural teeth mesial and distal to the implant site(s).*

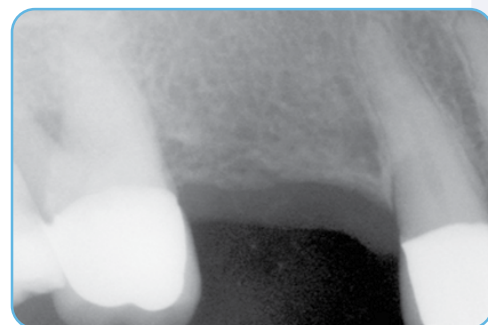

Photo courtesy of Dr. Pär-Olov Östman, Falun, Sweden.

Laboratory

1. Fabricate the diagnostic cast from the impressions of the patient. Pin the cast as it would be used in fixed prosthodontic procedures, including the edentulous area and the adjacent natural teeth. Pour the base of the cast in dental stone.

Create a translucent, non-rigid appliance on the diagnostic cast. Make linear perforations in the appliance where the implants are to be placed based on radiographic information, laboratory and clinically based discretion.



TIP: *The approximate position of adjacent tooth roots based on periapical and panoramic radiographs can be communicated to the dental laboratory by drawing or tracing them onto the diagnostic cast.*

Clinician

1. The patient is locally anesthetized and the surgical appliance is placed on the adjacent natural teeth.



2. A periodontal probe or a dental explorer is placed gently into each perforation of the appliance in order to create bleeding points. This is repeated into each one of the perforations.

Remove the appliance. Re-probe the bleeding points with the periodontal probe and an endodontic rubber stopper. Record the depths of each bleeding point for communication of tissue thickness and location of bone to the dental laboratory.

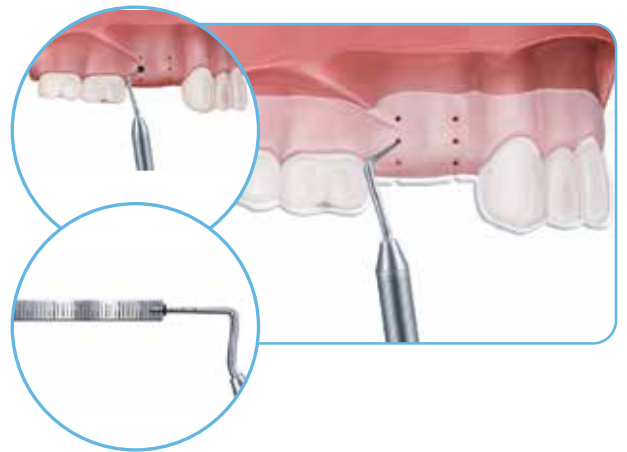

Laboratory Fabrication of the Master Cast

Laboratory

1. Place the appliance on the diagnostic cast. Use a pencil to mark the points on the cast through the perforations in the appliance.

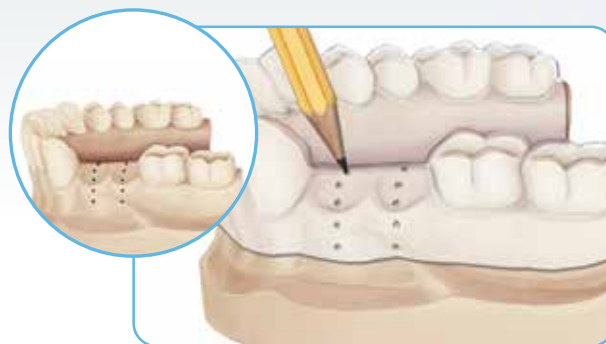

- 2a. In order to precisely reproduce the depths of the soft tissue intraorally, draw horizontal lines on the cast corresponding to the bleeding points.

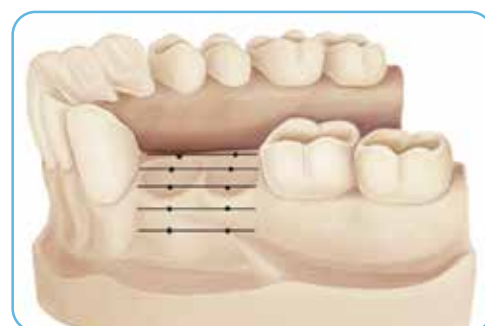

- 2b. Section the cast in the edentulous site at the planned center line of each implant. Record the depths of the soft tissue on the lateral aspects of the sectioned cast.

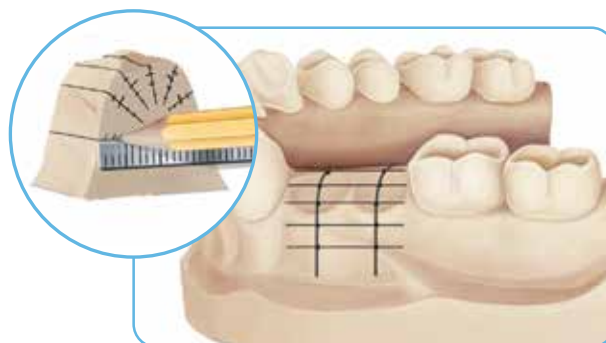

- 2c. Remove the stone with a laboratory handpiece and bur consistent with the depth of the soft tissue marked on the edentulous segment of the cast to create the bone profile for that site.



3. Create a receptacle for each implant analog by removing stone with a Laboratory Handpiece. The amount of stone removed should be consistent with the size of the Implant Analog(s) that will be placed into the cast for each implant. Attach the Implant Analog(s) to the sectioned portion of the cast with cyanoacrylate glue consistent with the planned placement of the implants: crestal, subcrestal or supracrestal. The position and angle of the Implant Analogs can be further evaluated with guide pins or laboratory screws.

This cast will now be used as the master cast for fabrication of the Surgical Guide and the provisional prosthesis in cases of immediate provisionalization.



4. Place healing abutment(s) onto the Implant Analog(s) consistent with the soft tissue height(s) recorded previously. The healing abutment(s) will be used to block out space prior to pouring the soft tissue portion of the cast.

TIP: Be sure to select a Healing Abutment height that will allow for full seating of the translucent appliance.



5. Mix an appropriate amount of "soft tissue material". Place the material into the appliance and re-seat the appliance back onto the stone cast. Fill the space between the master cast's bone profile and the appliance with the soft tissue material. Allow the material to set.



6. A Tissue Punch may be used to remove excess soft tissue material surrounding the Healing Abutments.

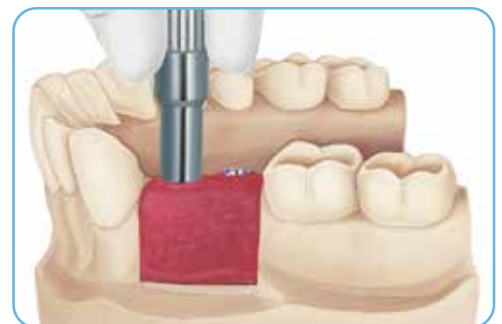

Fabrication of the Surgical Guide Based on the Laboratory-Made Master Cast

Laboratory

1. Generate the case-specific Surgical Plan (protocols) with the use of the ZimVie Dental Model-Based Surgical Plan Generator (Please see page 7 for further instruction). The implant catalog number (ex. IOSS410) for each site will be needed. Based on the planned implant, the program will provide the necessary Master Tube information and a list of compatible Analog Mounts to be used for each site. Choose the Analog Mount height that best suits the needs of the site and generate the Surgical Plan. This plan is also used during guided implant surgery.

Implant Label	10	11	13
Implant Reference Code	NIOSS411	NIOSS413	NIOSS510
Planned Implant Diameter (mm)	4	4	5
Planned Implant Length (mm)	11.5	13	10
Implant Placement			
Depth Line	(2)	(3)	(3)
Tissue Punch	4	4	5
Starter Drill	4	4	5
Drill / Handle	2.0(B) / 1	2.0(C) / 1	2.6(B) / 3
Drill / Handle	3.0(B) / 2	3.0(C) / 2	3.35(B) / 4
Drill / Handle	---	---	3.85(B) / 4
Tap	4	4	5
Implant Mount	4(2)	4(3)	5(3)
Bone Prolifer	4	4	5
Analog Placement			
Analog Mount	4(2)	4(3)	5(3)
Analog Type	HLA30	HLA30	HLA55

2. Select the agreed upon Analog Mount from the Navigator Laboratory Kit for each implant. Place the Analog Mount(s) through the specified Master Tube(s) and engage the anti-rotational positioning pin of the Analog Mount into the notches of the Master Tube(s). Place the Implant Analog Mount(s) into each Implant Analog and thread the thumb screws into the mounts approximately 2 turns. The Analog Mount will expand to secure itself within the Master Tube.



TIP: Position the Analog Mount into the Implant Analog so that the anti-rotational positioning pin is facing toward the buccal aspect. This will allow for optimal visibility of the notches of the Master Tube(s) during implant placement.

3. Check the positions of the Master Tube(s) and Implant Analog(s). Use silicone putty to block out the spaces above and below the Master Tube(s) and the Implant Analog(s), leaving the Master Tube(s) exposed. The remaining undercuts on the master cast should also be blocked out with silicone putty. Lubricate the exposed surfaces of the teeth on the cast.



4. Mix and place autopolymerizing clear acrylic resin onto the exposed surfaces of the teeth and the Master Tube(s) on the master cast. There must be sufficient resin for the Surgical Guide to be stable and resistant to fracture. The acrylic resin should not extend into any undercuts.



5. Place the cast (with the Surgical Guide in place) into hot water (120° F) for 10 minutes. Remove the Surgical Guide from the cast, finish and polish. Make sure the occlusal surfaces of the Master Tube(s) are completely free of debris and acrylic resin.



6. Prepare two to four windows into the occlusal surface of the Surgical Guide in order to confirm correct seating of the Surgical Guide on the teeth during surgery. The windows should be monitored for optimal seating throughout the surgical procedure.

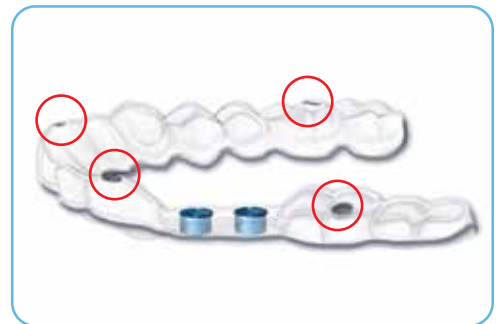

Laboratory Abutment Selection

Laboratory

1. Measure the periimplant soft tissue depths around each Implant Analog. Select an interim abutment for optimal margin location (at the gingival crest, sub-gingival or supra-gingival). Select a provisional abutment consistent with cement- or screw-retention.
2. Measure the periimplant soft tissue depths around each Implant Analog. Select an interim abutment for optimal margin location (at the gingival crest, sub-gingival or supra-gingival). Select a provisional abutment consistent with cement- or screw-retention.
3. The provisional restorations may be delivered according to implant loading protocols determined by the clinician (Immediate Non-Occlusal Loading, Immediate Occlusal Loading). The restorations may be splinted or fabricated as individual units. Adjust the occlusion as indicated. If a flap procedure was used during surgery, suture the tissue around the provisional restoration

Please refer to the Navigator Manual for more information regarding options for immediate provisionalization of Navigator Cases.



For more information, visit [ZimVie.com](https://www.ZimVie.com)

ZimVie US Corp LLC
4555 Riverside Drive
Palm Beach Gardens, FL 33410
Phone: +1-561-776-6700
Fax: +1-561-776-1272
dentalCS@ZimVie.com



Unless otherwise indicated, as referenced herein, all trademarks and intellectual property rights are the property of ZimVie Inc. and its affiliates; and all products are manufactured by one or more of the dental subsidiaries of ZimVie US Corp LLC (Biomet 3i, LLC, etc.) and distributed by ZimVie US Corp LLC and its authorized marketing partners. EU Medical device classification: Navigator Surgical Kit (IIa). The Intended purpose of the Navigator Surgical Kit is to facilitate the implantation and explantation of Dental Implants. The products here shown are not eligible for reimbursement in France. For other countries, please check the local laws and regulation. For additional product information, please refer to the individual product labeling or instructions for use. Product clearance and availability may be limited to certain countries/regions. This material is intended for clinicians only and does not comprise medical advice or recommendations. Distribution to any other recipient is prohibited. This material may not be copied or reprinted without the express written consent of ZimVie.
ZVINST0161-GLBL REV D 11/25 ©2025 ZimVie. All rights reserved.

